

# HUMIDIFICATION

## WINE CELLAR COOLING SYSTEMS



## Preserve your collection of fine wine with a finer cooling system.

As with all Wine Guardian® products, our humidifiers are uniquely designed to deliver superior performance and reliability, just what you need to ensure that your fine wine collection ages as its finest.



### Humidifier features

All Wine Guardian humidifier models include the following:

- Digital controls work off of Wine Guardian's remote indicator. There's no need for separate controller.
- Evaporative drip pad system with removable, cleanable pad
- Built-in fans for optimal air circulation
- Commercial grade and lightweight, corrosion-resistant components
- 25 feet (8 meters) of control cable pre-wired to the unit for easy plug in
- Drip pad access cover for easy maintenance
- Warranted to two years (parts) and one year (labor)
- Made in the USA

### Additional features:

#### Integrated Model

- Installs on either side of system for application flexibility
- 24-volt power directly from Wine Guardian unit; no separate power source required
- Uses same WG remote interface for control and readout

#### Freestanding (for all models including Through-the-Wall)

- Sleek, modern supply grille (removable)
- Can be mounted through the wall, through the racking or on the wall for installation flexibility
- Includes sealed, plug-in transformer and lead cord to allow the unit to operate independently of the cellar cooling system
- Can be used with competitive wine cooling systems

### Models



Humidifier integrated with ductable split system shown on evaporator section (also available on ducted systems)



Freestanding (wall-mounted) humidifier



Freestanding (through-wall mounted) humidifier



AIR INNOVATIONS Wine Guardian® is a registered trademark of Air Innovations®



# HUMIDIFICATION

## WINE CELLAR COOLING SYSTEMS

### What you need to know about Wine Guardian humidifiers

- Wine Guardian's humidifiers are specifically designed for wine cellars. They are easy to install and operate, as either freestanding or integrated units.
- Wine Guardian uses the WG control system to sense and control the amount of moisture that needs to be added to the cellar.
- Water supply and drain lines are conveniently located for ease of installation and service.
- Humidifier can be mounted within the racking, through wine cellar wall or mounted to a wall using the appropriate mounting bracket.
- Wine Guardian humidifiers are designed for minimal maintenance. However, a regular maintenance program prolongs the life of the humidifier and helps maintain the humidity in the cellar.
- Your authorized Wine Guardian distributor can assist you in specifying the correct model for your cellar's particular needs.

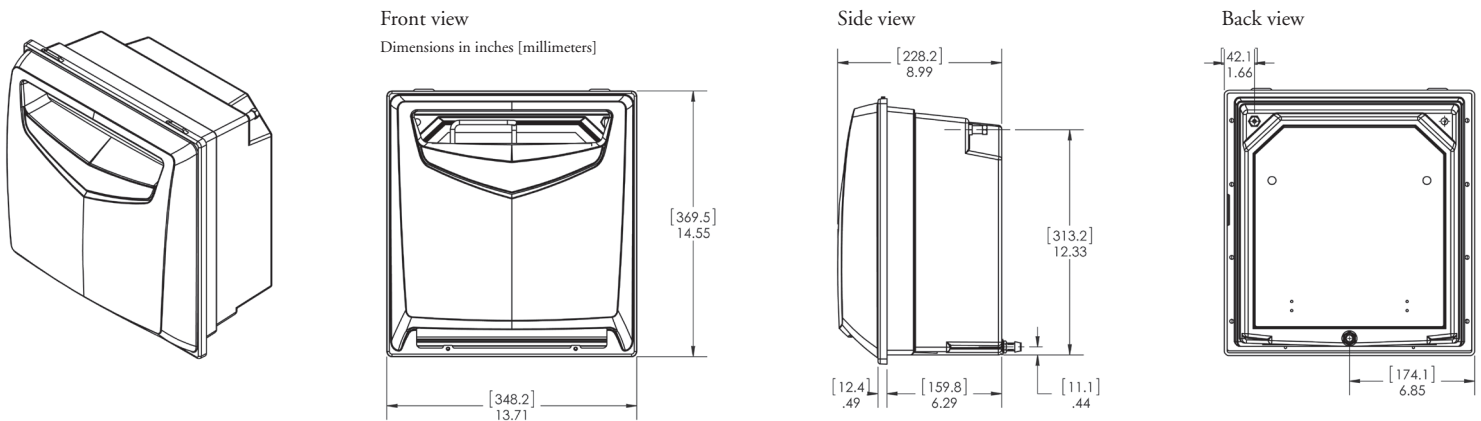

## HUMIDIFIER SPECIFICATIONS

### Removable drip pad with integral fan

Supply water	Temperature 60 Deg F (16 Deg C) 100 Deg F (38 Deg C)	Capacity 0.42 lbs/hr (0.19 kg/hr) 1.0 lbs/hr (0.45 kg/hr)
Controls	Cellar-mounted Wine Guardian remote interface controller	
Power Requirements	115 volt, 1 phase, 60 hz (220/240 volt, 1 phase) as freestanding 24-volt (24-volt), direct connected to Wine Guardian	
Weight	10 lbs (4.5 kg)	

Contact your authorized Wine Guardian distributor for information pertaining to integrated humidification.

Wine Guardian® systems are made in the USA by Air Innovations®. Manufacturer reserves right, without notice, to make changes to specifications at its sole discretion.

Wine Guardian® Through-the-Wall Cooling System US Pat. No. D634760.

EasyMount™ is a trademark of Air Innovations. Wine Guardian® is a registered trademark of Air Innovations®.

Rev. January 2013